

# Service Manual

Radio Cassette  
**RX-FT510**

Stereo Radio Cassette Recorder

Color

(K) . . . . . Black Type



## Area

Country Code	Areas	Color
(E)	Continental Europe	(K)
(EB)	Great Britain	
(EG)	F.R. Germany/Italy	

## MECHANISM SERIES (SG-20)

### ■ SPECIFICATIONS

#### General:

Power Requirement: AC; (E) (EG).....220 V, 50 Hz  
(EB).....240 V, 50 Hz  
Battery; 9 V (Six UM-1, Batteries)

Power Consumption: 16 W (AC only)

Power Output: 20 W (10 W x 2)...PMPO

Speaker: Woofer; 10 cm PM Dynamic Speaker (2.7Ω)  
Tweeter; 1.5 cm Ceramic Speaker

Jacks: Input; CD/LINE IN; 398 mV, 47 kΩ  
Output; HEADPHONES; 32Ω, ø3.5

Dimensions (W x H x D): 566 x 156 x 167 mm

Weight: 3.1 kg without batteries

#### Radio Section:

Radio Frequency Range: FM; 87.5 ~ 108 MHz  
MW; 520 ~ 1610 kHz  
SW; 5.9 ~ 18 MHz  
LW; 148.5 ~ 285 kHz

Intermediate Frequency: FM; 10.7 MHz  
AM; 459 kHz

Sensitivity: FM; 2.5 μV/50 mW output  
MW; 125 μV/m/50 mW output  
SW; 3.2 μV/50 mW output  
LW; 180 μV/m/50 mW output

#### Tape Deck Section:

**TAPE 1**  
Frequency Response: 70 ~ 12,000 Hz  
Tape Speed: 4.8 cm/s  
Track System: 4-track 2-channel stereo playback

#### Tape Deck Section:

**TAPE 2**  
Frequency Response: 70 ~ 12,000 Hz  
Tape Speed: 4.8 cm/s  
Recording System: AC bias, Magnet erase  
Track System: 4-track 2-channel stereo recording and playback

#### Notes:

1. Weights and dimensions shown are approximate.
2. Design and specifications are subject to change without notice.

# Panasonic

# SCHEMATIC DIAGRAM (Parts List on Page 21, 22 and 23)

1 2 3 4 5

## B TUNER CIRCUIT

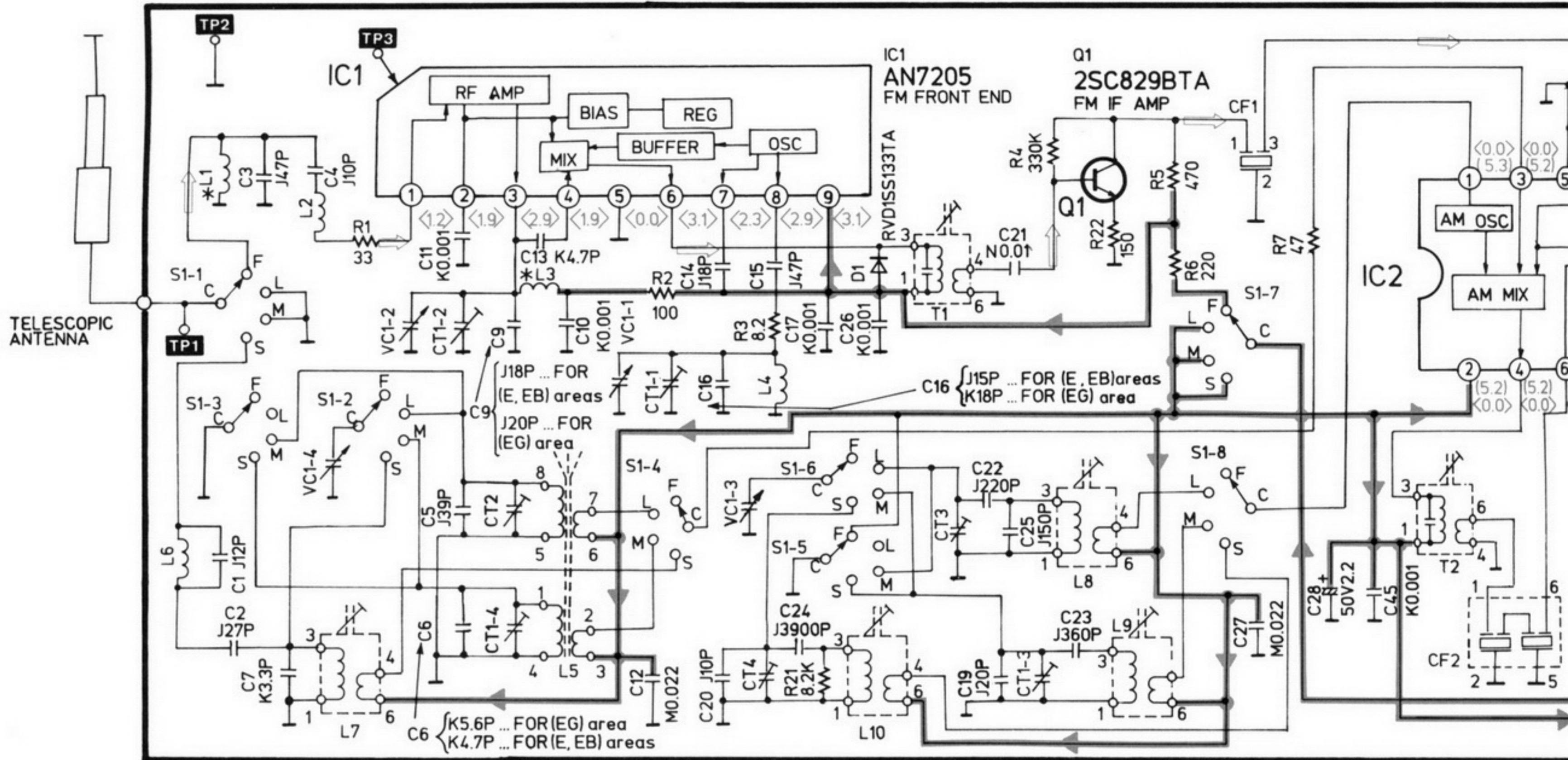

## A MAIN CIRCUIT

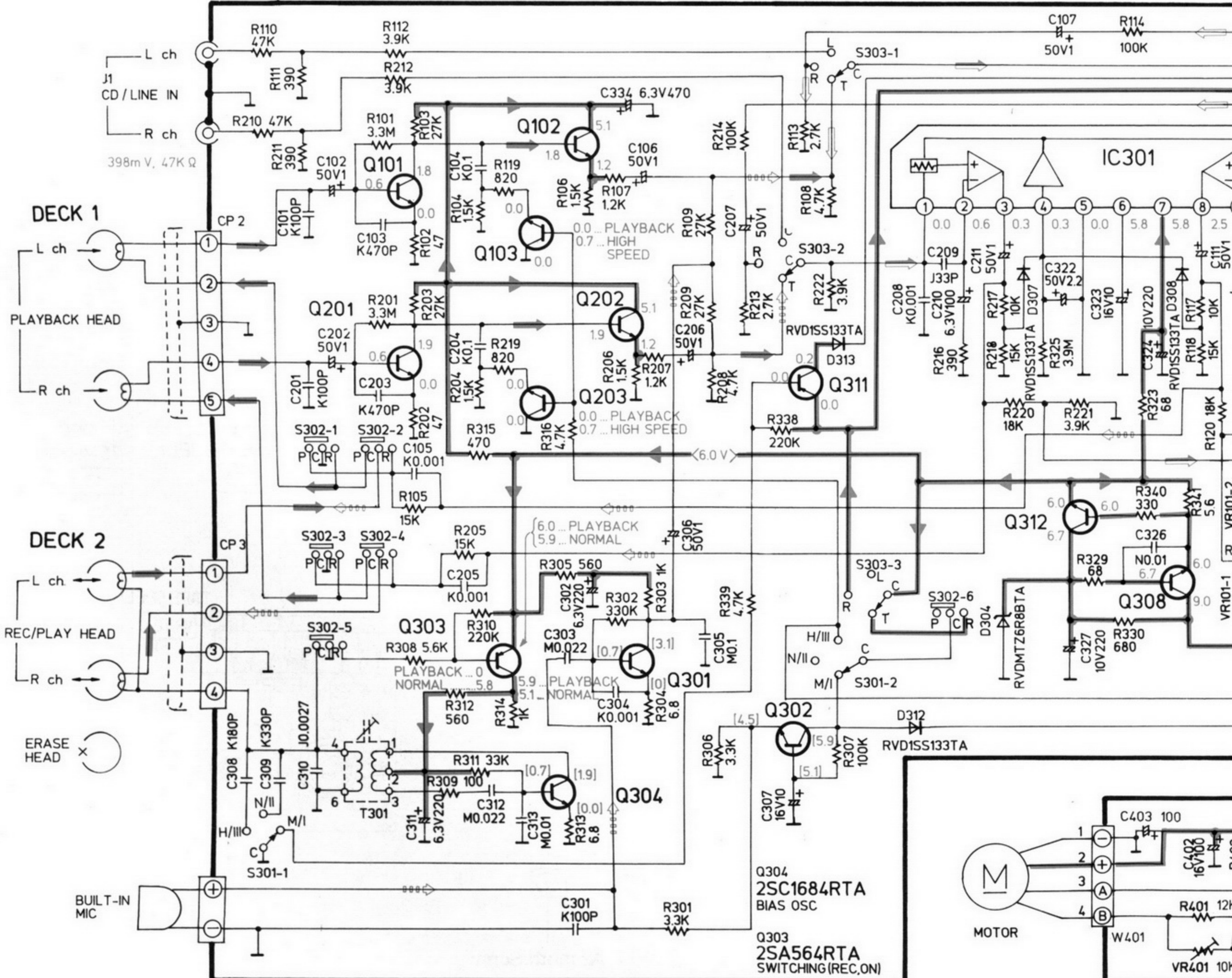

C MECH

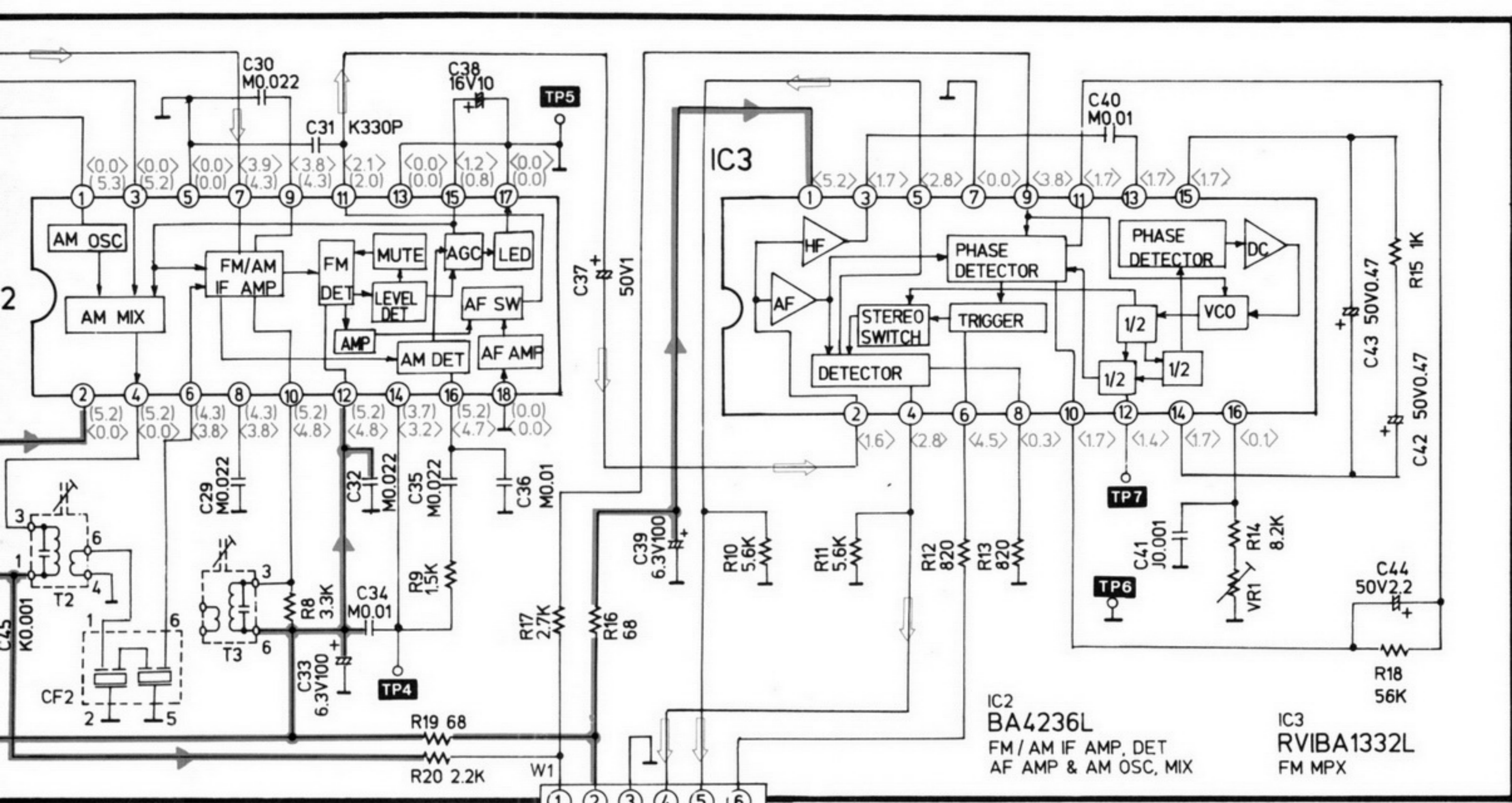

**E** LED CIRCUIT

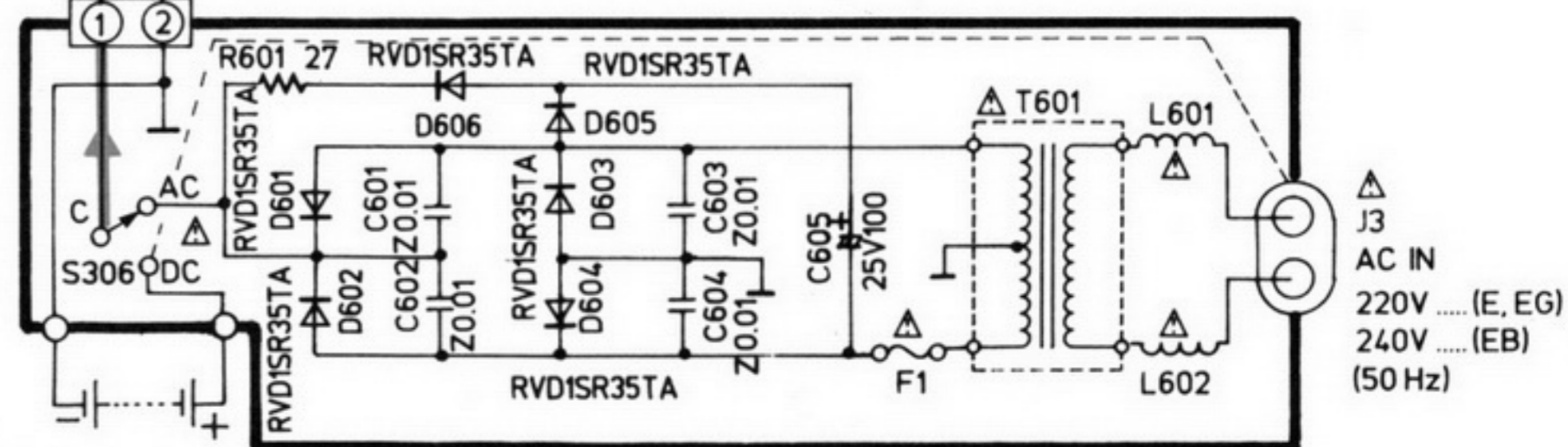
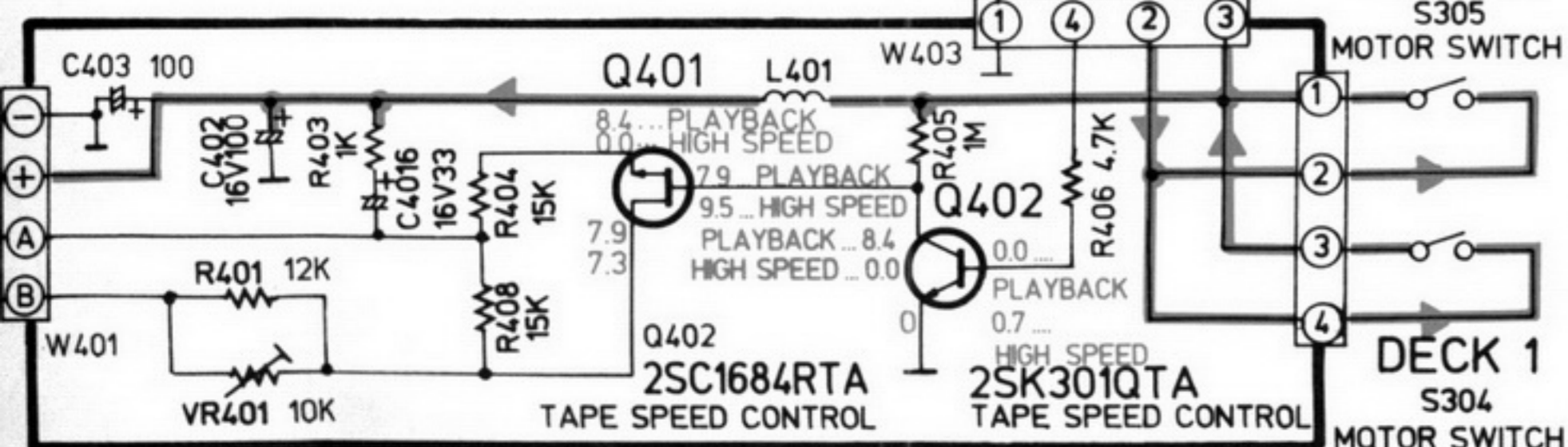
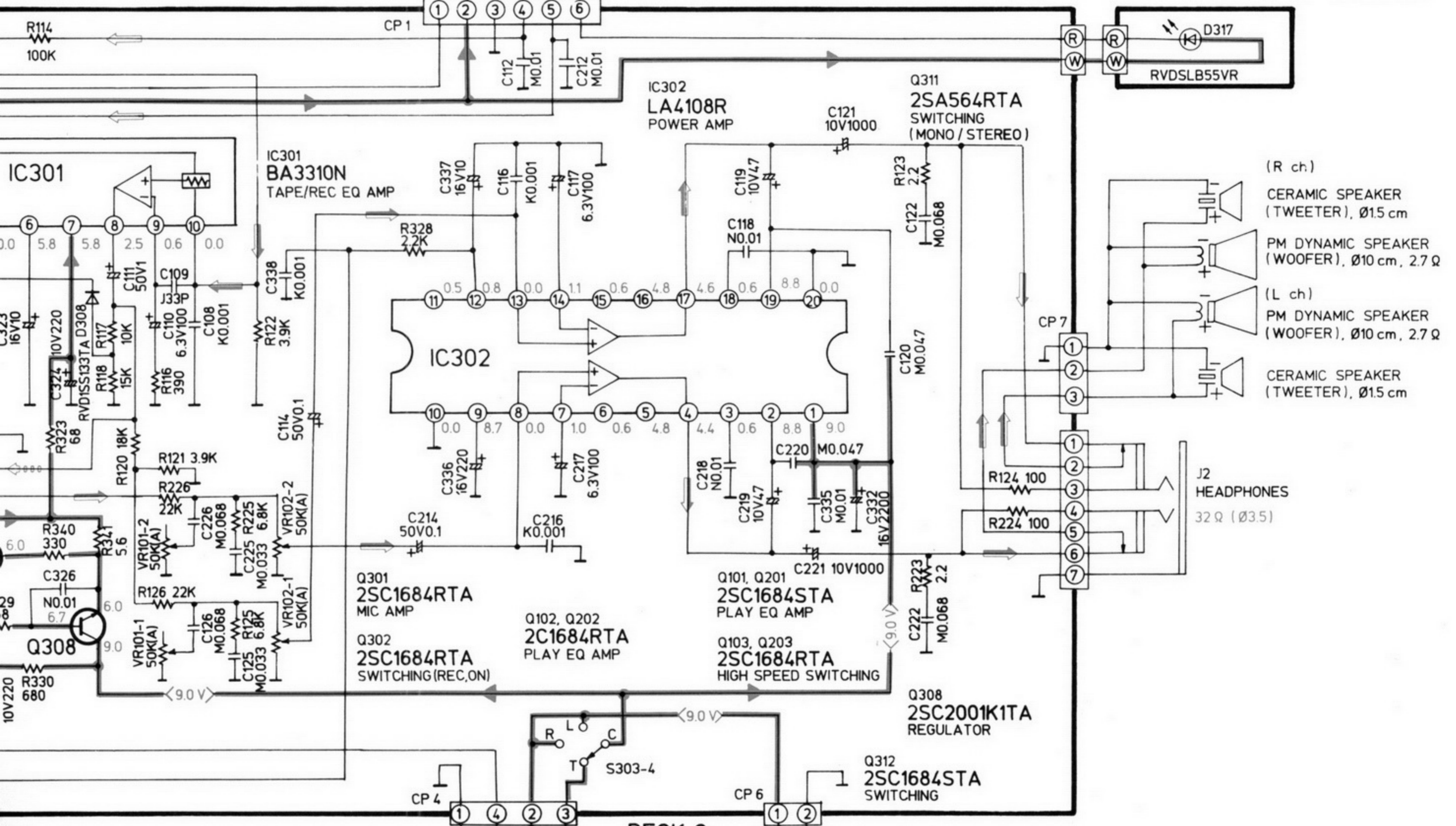

**C** MECHANISM CONTROL CIRCUIT

BATTERY 6 UM-1 BATTERIES 9V

**D** POWER SUPPLY CIRCUIT

