



Portable Cassette Recorder With Auto-Stop

# MODEL M-741D

## SERVICE MANUAL

SANYO ELECTRIC TRADING CO., LTD.  
SANYO ELECTRIC CO., LTD.  
OSAKA, JAPAN



### SPECIFICATIONS

Recording system.....	AC bias
Erasing system.....	AC erase
Tape.....	Universal compact tape cassettes
Tape speed.....	1-7/8 ips (4.75 cm/sec.)
Fast forward & Rewind time.....	1 min. 45 sec. (C-60 cassette)
Frequency response.....	50 - 10,000Hz
Signal-to-noise ratio.....	43 dB
Output power.....	1,500mW max.
IC.....	1
Transistors.....	5
Diode.....	5

Connectors:.....	MIC input	1.5K ohms
	DIN input	14K ohms ms
	output	1.6K ohms
	EXT, SP (earphone)	8 ohms
Loudspeaker.....	3-3/8" diameter,	8 ohms
Power source.....	DC:	9V (C x 6)
	AC:	120/200/240V, 50/60Hz
Dimensions.....	8-11/16"(W)x2-9/16"(D)x7-5/8"(H)	
	(220 x 65 x 192mm)	
Weight.....	4.7 lbs. (2 kg) approx.	

### MAINTENANCE (Fig. 1)

After approximately 300 hours of operation. Clean the following parts using methyle alcohol. Never use an abrasive or a metallic object for eaning.

- Record/Play (201) and Erase heads (202).
- Capstan (24).
- \* Rubber surfaces of turntable (4) & (5).
- \* Rewind roller (26)
- \* Drive belt (44).
- \* Pinch roller (9).
- \* Groove of take-up pulley (3).
- \* Idler roller (25).
- \* Groove of motor pulley (206).

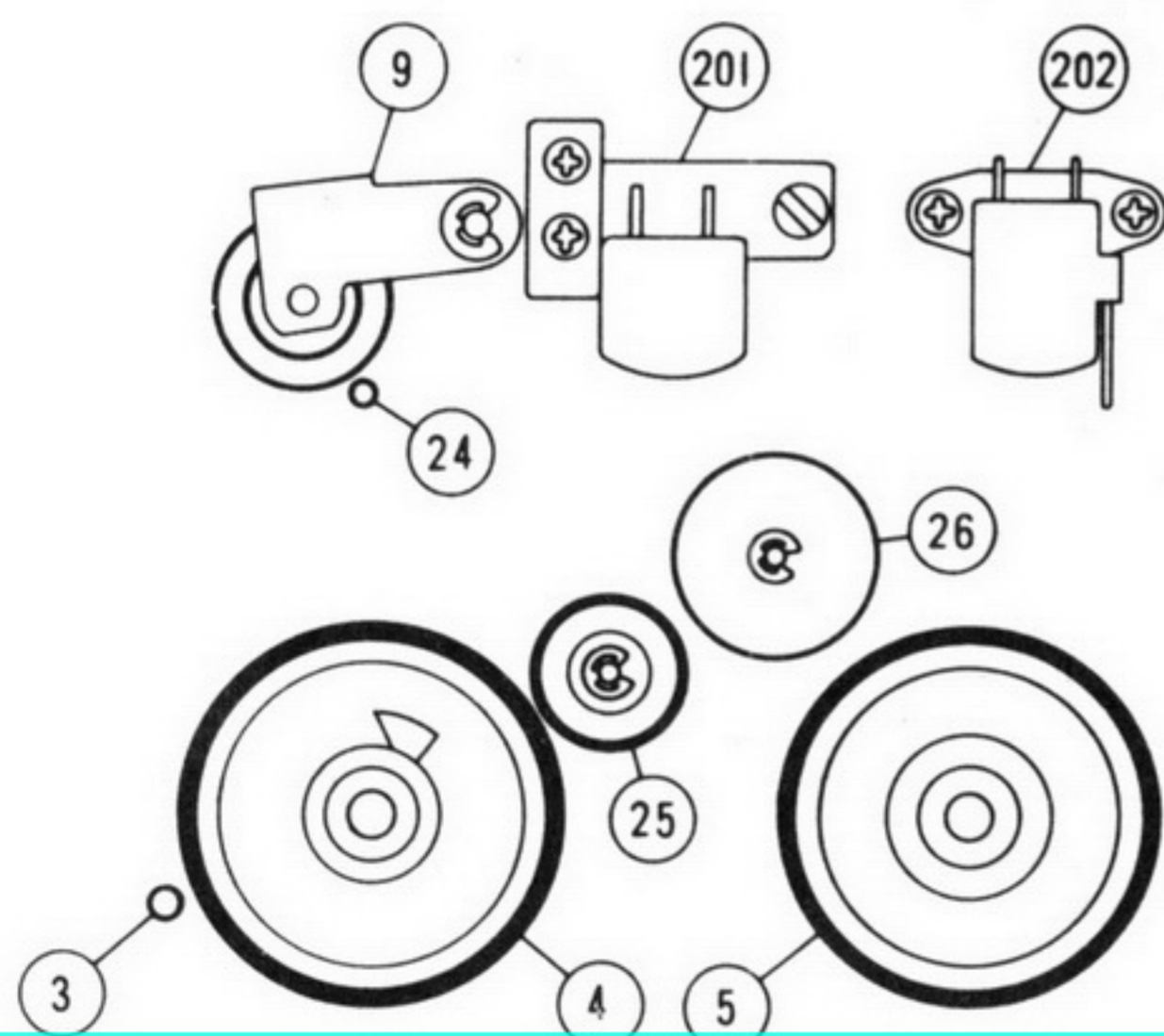

Fig. 1

### RECORD/PLAYBACK & ERASE HEADS ADJUSTMENT (Fig. 2)

Whenever the heads are removed and/or repaired, perform the head penetration and azimuth adjustments as instructed below.

Head penetration adjustment:

1. Measure the gap between the record/playback head (201) and cassette fixing pin (1), this gap should be 0.2mm when the recorder is in the PLAY mode. And also measure the gap between the erase head (202) and cassette fixing pin, this space should be 0.1mm in the PLAY mode.
2. If not, loosen the screw (three for R/P head, two for erase head) and adjust the position of heads so that required clearances are obtained.

Head azimuth adjustment (R/P head only):

1. Connect the power source to the unit and insert the BASF test tape (6.3 KHz pre-recorded) or other test tape for head azimuth adjustment (6.3 KHz recorded) into the cassette compartment.
2. Allow the unit to go into the PLAY mode.
3. Connect an 8 ohm dummy load with the V.T.V.M. across it to Earphone jack on the recorder.
4. Adjust the head azimuth adjusting screw (107) for maximum reading on the V.T.V.M.
5. After the above adjustment is completed, apply a drop of paint or glue on the adjusting screw.

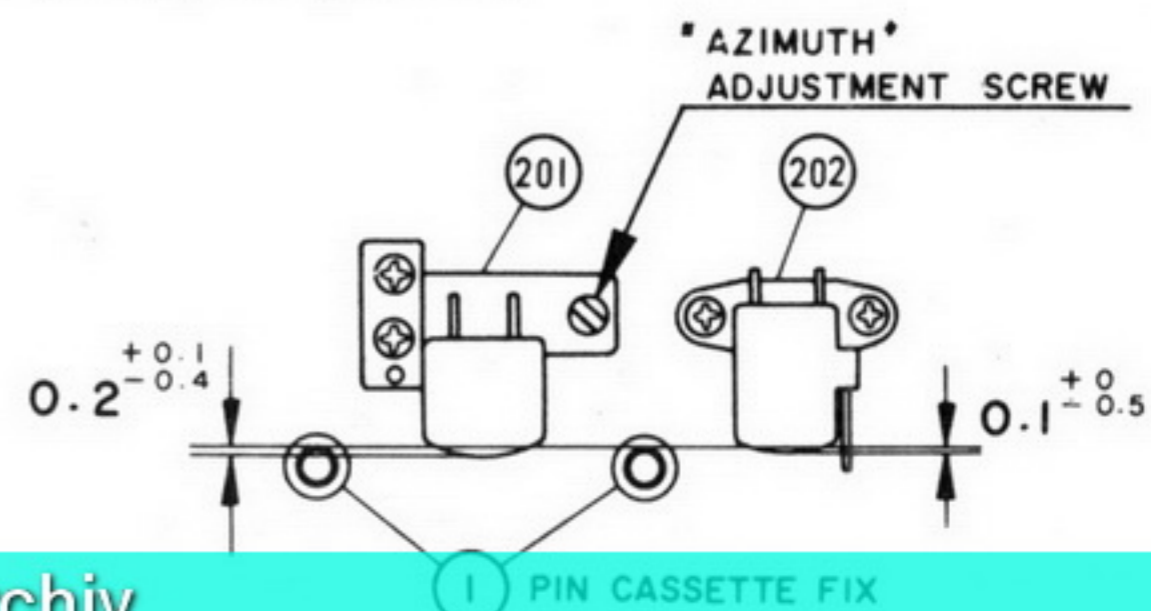

Fig. 2

**SCHEMATIC DIAGRAM**

