

Service Manual

Cassette Recorder

M W235LET (EUROPE)
(W.GERMANY)
(SPAIN)



Specifications

PRODUCT CODE No.

142 839 55 (EUROPE)
142 839 56 (W.GERMANY)
142 839 57 (SPAIN)

Recording system AC bias, 4-track stereo	Frequency response	80 - 14,000 Hz
Erasing system Magnet erase, 2 - track	Output power	... 11 W (P.M.P.O.) 3.5 + 3.5 W (MUSIC POWER)
Tape speed 4.75 cm / sec.	Power source	... DC : 9 V, "R20 (D / HP2)" × 6 batteries AC : 120 / 220 V, 50 / 60 Hz
Frequency range MW : 522 - 1,611 kHz LW : 144 - 288 kHz FM : 87.5 - 108 MHz	Dimensions Approx. 683(W) × 210(H) × 173(D) mm
Terminal impedance PHONES : 32 ohms EXT SPEAKER : 2.7 - 8 ohms CD / LINE - IN : 47 kohms	Weight Approx. 5.1 kg including batteries

Specifications subject to change without notice.

REFERENCE NO. WM-580412

SCHEMATIC DIAGRAM (TUNER)

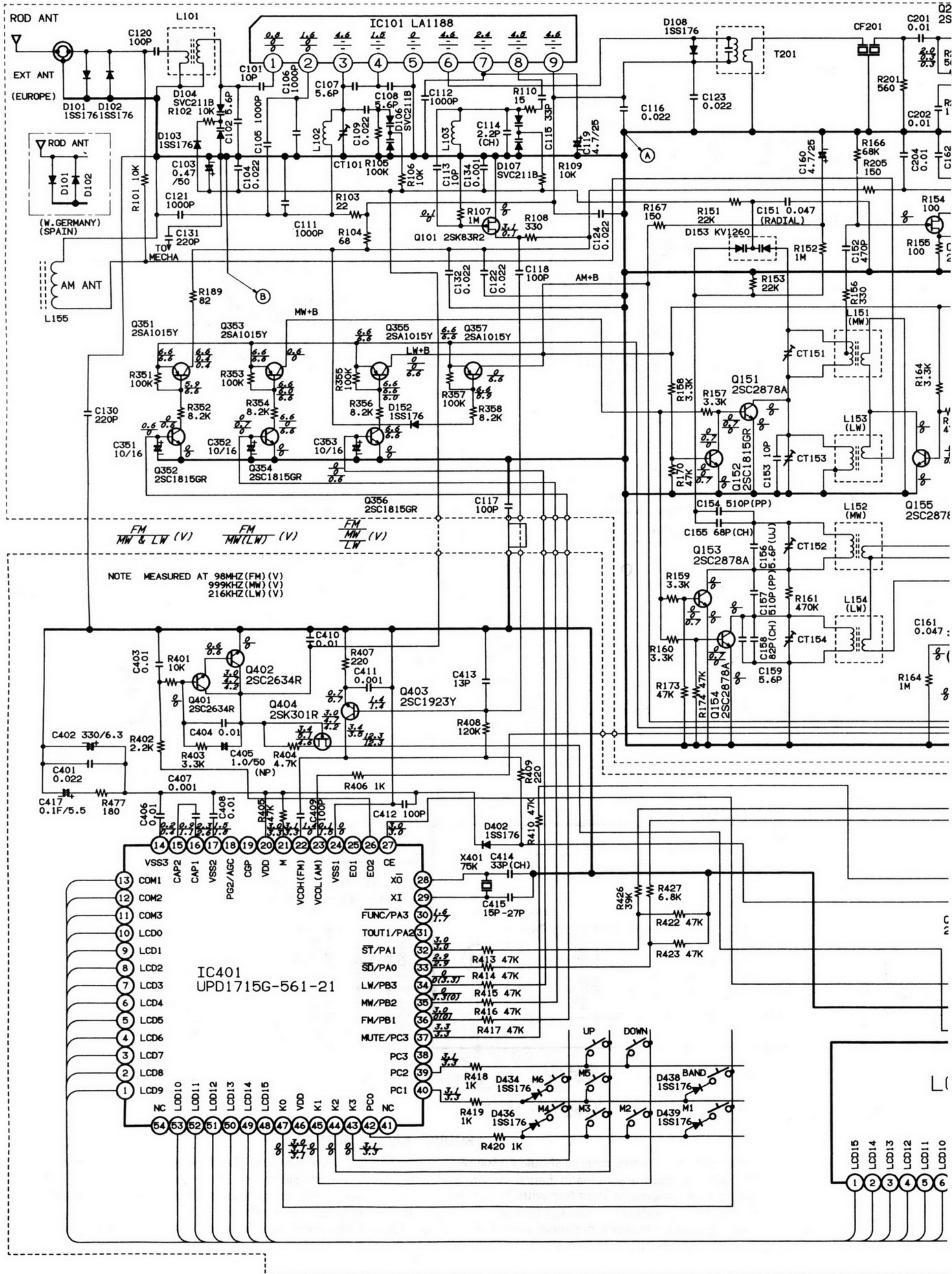

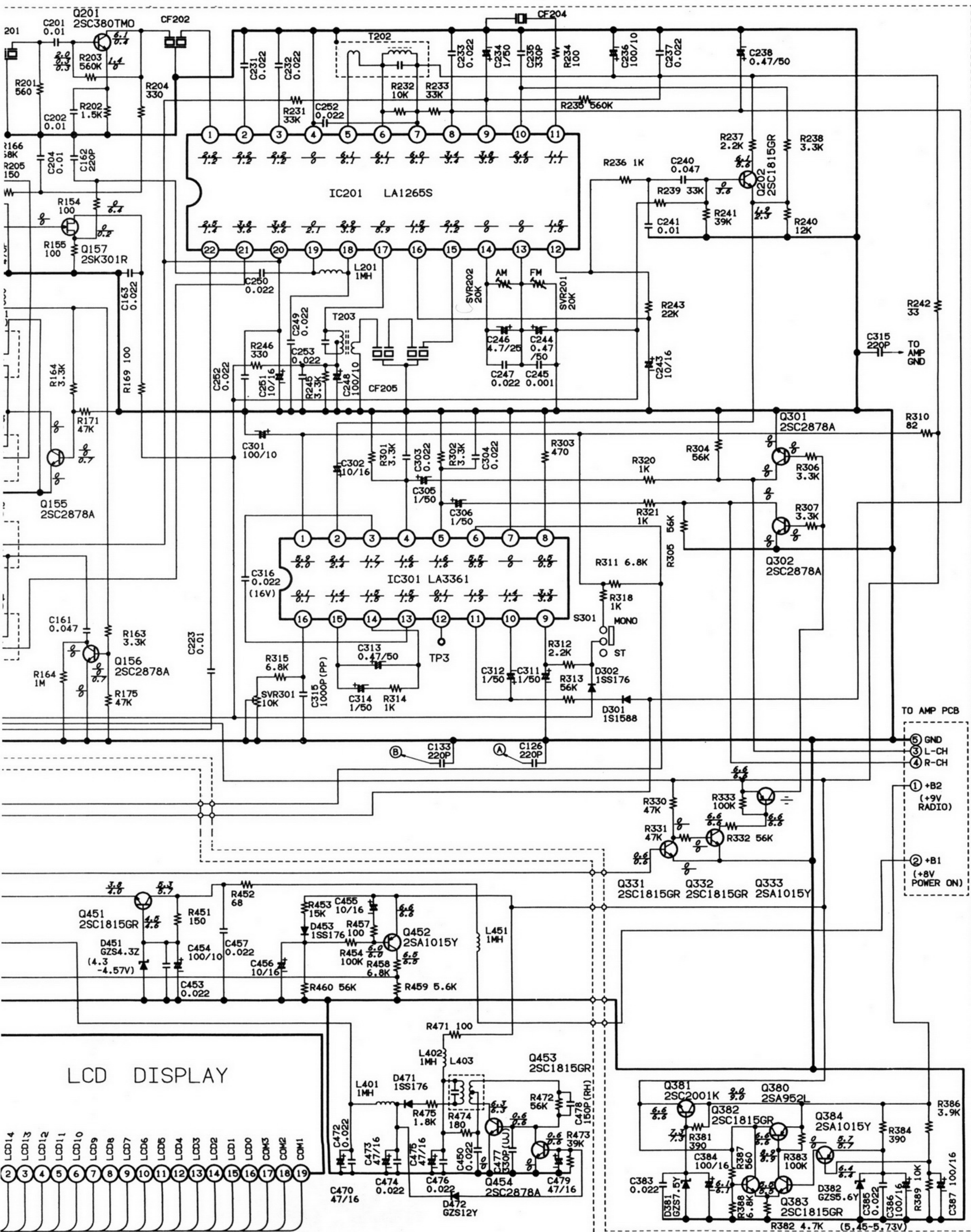

SCHEMATIC DIAGRAM

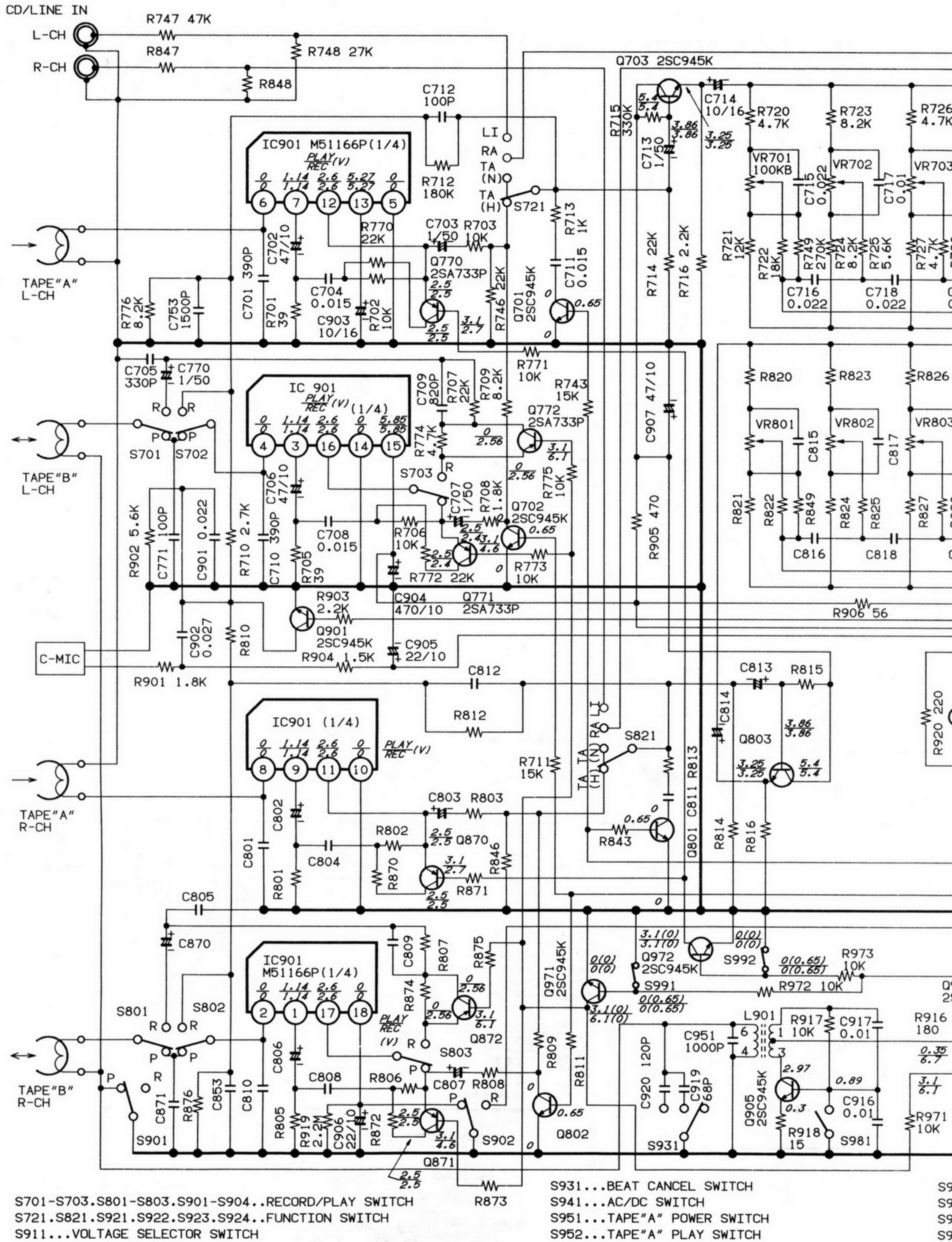

S701-S703.S801-S803.S901-S904..RECORD/PLAY SWITCH
 S721.S821.S921.S922.S923.S924..FUNCTION SWITCH
 S911...VOLTAGE SELECTOR SWITCH

S931...BEAT CANCEL SWITCH
 S941...AC/DC SWITCH
 S951...TAPE "A" POWER SWITCH
 S952...TAPE "A" PLAY SWITCH

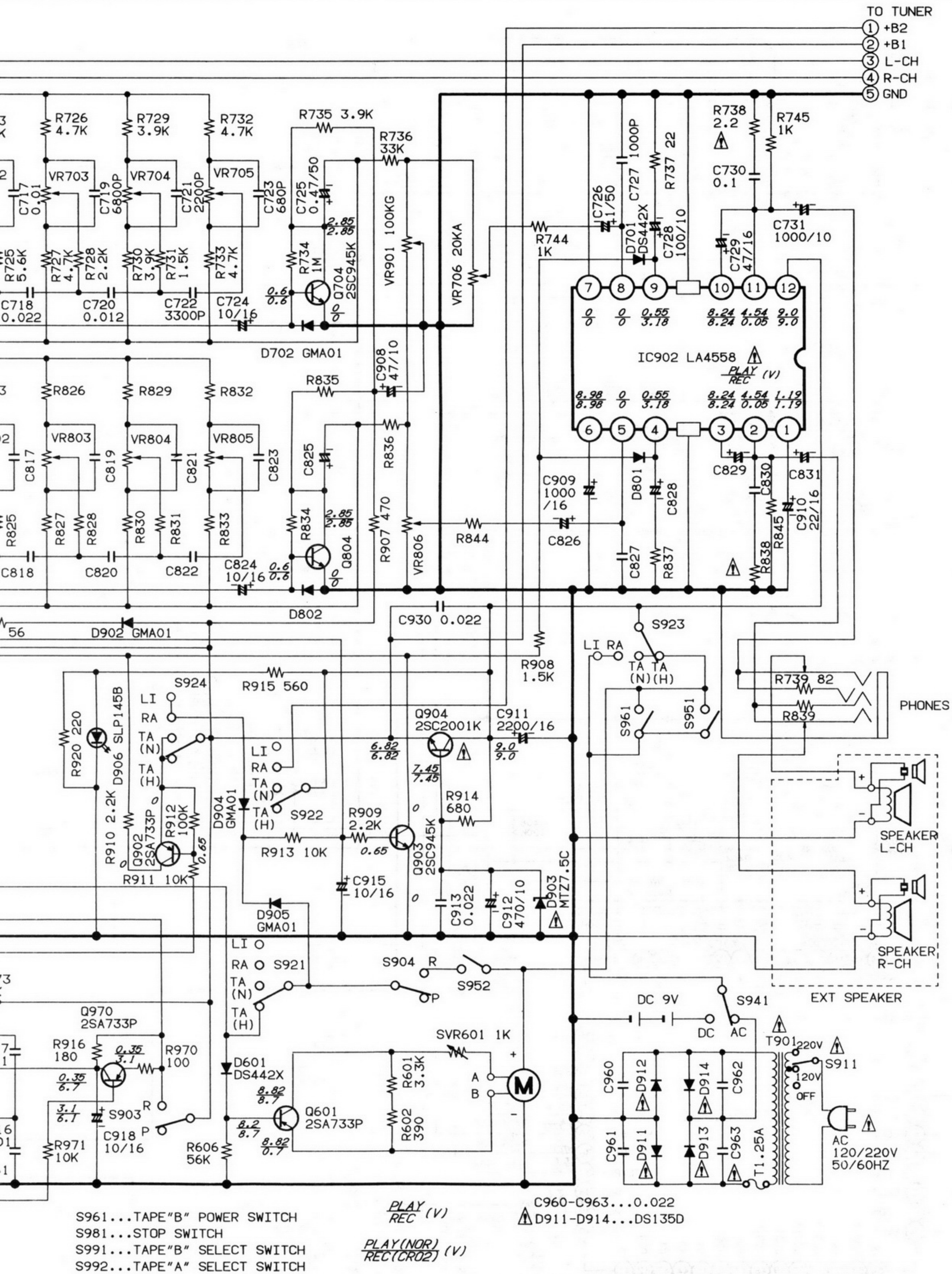

PRODUCT SAFETY NOTICE

Each precaution in this manual should be followed during servicing. Components identified with the IEC symbol Δ in the parts list and the schematic diagram designate components in which safety can be of special significance. When replacing a component identified with Δ , use only the replacement parts designated, or parts with the same ratings of resistance, wattage or voltage that are designated in the parts list in this manual. Leakage-current or resistance measurements must be made to determine that exposed parts are acceptably insulated from the supply circuit before returning the product to the customer.